

QUANTUM POWER MODULE

A - B - BC - BP - G - GC - Z

INSTRUCTIONS

MODULE SELECTION

A list of the flashes (or flash) compatible with your module is located on the side of the power module box. If your flash is not listed, consult your dealer for a module suitable to your flash. Although modules may look similar, they are not interchangeable. For example, a Module G cannot be used with a flash requiring a Module B. Trying to do so could damage your flash.

MODULES A, G / VIVITAR FLASHES

Modules A and G are supplied with a special clip to be used with all Vivitar flashes (except model 636). If you are not using a Vivitar flash, remove the clip. (For complete information, see Special Instructions for Vivitar Flashes.)

MOUNTING THE POWER MODULE INTO YOUR FLASH

The module you have just purchased looks like a square cluster of four batteries and, just like batteries, it must be positioned inside the flash properly.

The Power Module Location Chart is a guide for positioning the module inside your flash. Check the four columns of the chart to see if your flash is listed and, if it is, follow the instructions for the chart. If your flash is not listed on the chart, use the instructions inside the box to the right titled "Only For Flashes Not Listed on the Module Location Chart".

MODULE LOCATION CHART INSTRUCTIONS

When using the Module Location Chart, please note that the flash diagram used represents a typical flash. Your flash may look slightly different. The flash head may be in a fixed position or may swivel to the right or left. Keeping that in mind, hold your flash as shown in the diagram, with the battery compartment towards you, the flash head at the top, and the hot shoe mount at the bottom.

1. Remove the AA batteries from your flash.
2. Turn the flash ON. Turn the Quantum Battery OFF.
3. Locate your flash model number in one of the four columns. Note the position of the red marker in the corresponding diagram. Place the module inside your flash with the red marker in the same position.
4. Plug the proper module for your flash into either output of the Quantum Battery 1.
5. Turn the Quantum Battery ON. The indicator on the flash should light and/or you should hear the "whine" of the flash recycling.

***IF YOUR FLASH DOES NOT RESPOND INSTANTLY,
TURN THE QUANTUM BATTERY OFF IMMEDIATELY.***

Check the model number on your flash and the four columns of the chart again. If you still have trouble, consult your dealer or contact us for assistance before proceeding. Do not risk damage to your flash.

6. Once you have determined the correct position, place one of the red "dot" stickers on the flash next to the red marker on the module.
-

ONLY FOR FLASHES NOT LISTED ON THE MODULE LOCATION CHART

Read thoroughly and understand how to determine if you have the correct or incorrect (wrong) position before proceeding.

1. Remove the AA batteries from your flash.
2. Turn the flash ON. Turn the Quantum Battery OFF. Plug the module into either flash output of the Quantum Battery.
3. The Module can be positioned inside the flash in four different ways; only ONE is correct. To determine which one of the four positions is correct, place the module inside the flash. (Select any position). Turn the Quantum Battery ON for a MAXIMUM of ONE SECOND.

IF THE FLASH IS NOT POWERED UP THE INSTANT THE QUANTUM BATTERY IS TURNED ON, TURN THE QUANTUM BATTERY OFF IMMEDIATELY.

You can tell if the flash is powered properly by any of the indicators on your flash lighting or by listening for the "whine" of the flash unit recycling.

4. If you have the wrong, or incorrect, position there will be no indication of flash power. Possibly, the short circuit "STOP!" indicator on the Quantum Battery will light up. Caution: leaving the module incorrectly connected to the flash, with the Quantum Battery turned ON, could damage your flash
5. Once you have determined the correct position, place one of the red "dot" stickers on the flash next to the red marker on the module.

POWER MODULE LOCATION CHART

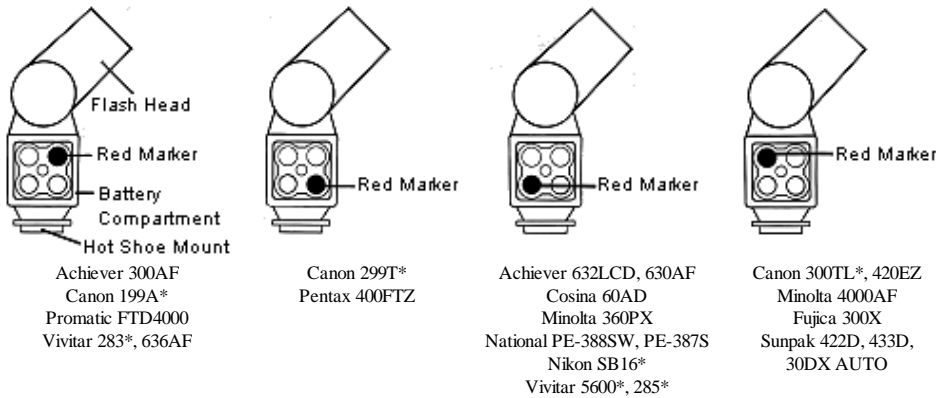

*See section - SPECIAL INSTRUCTIONS.

INCLUDED WITH YOUR MODULE

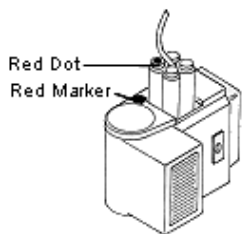

RED DOT STICKERS

After you have properly located the module inside your flash, place one of your red "dot" stickers on your flash next to the red marker on the power module as a reminder for future use.

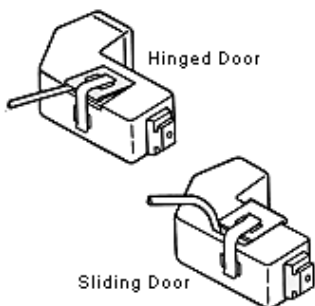

VELCRO

To secure the Power Module, place one adhesive-backed piece on the flash and the other on the battery compartment door. Use the 4" long (10cm) piece to secure the door.

SPECIAL INSTRUCTIONS

MODULES A, G / VIVITAR FLASHES

Power Modules A and G are supplied with a special clip to be used with all Vivitar Flashes (except model 636). When using the clip, the module can be inserted only one way.

If you are not using a vivitar flash, remove the clip (diag. 1).

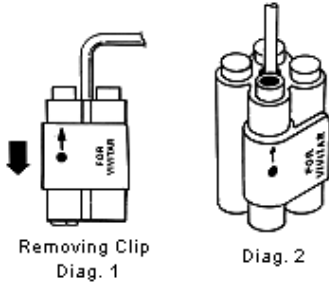

When replacing the clip, snap it onto the module as shown (diag. 2). The red marker on the clip should point to the red marker on the module.

CANON 199A / POWER MODULE A

NIKON SB16 / POWER MODULE G

A special spacer plate has been included to insure positive contact with your flash. Place the spacer plate on top of the module and slide the battery compartment door into place.



CANON 300TL / POWER MODULE GC

Power Module GC is supplied with a special locking plate. Slide the locking plate under the three tabs on the flash as shown.

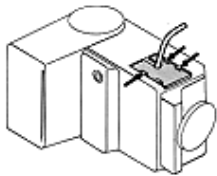

CANON 299T / POWER MODULE BC

Locate the locking plate tabs between the tabs on the flash. Slide into place as shown.

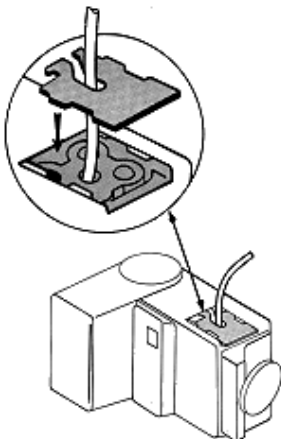

HOW TO SECURE MODULES BC & GC

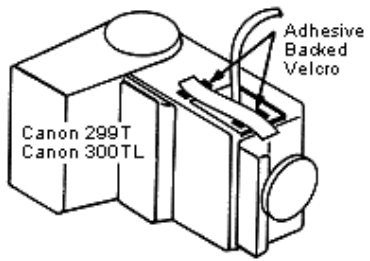

Place one adhesive backed piece of Velcro on the flash and the other on the Locking Plate (provided with the module).

Use the 4" long (10 cm) piece to secure the Locking Plate.