

QUANTUM POWER MODULE MF3 & XF3

INSTRUCTIONS

INTRODUCTION

Modules MF3 and XF3 were specially designed for use with the Canon 380EX flash.

Module MF3 - for use with the Quantum Battery 1+/1.

Module XF3 - for use with the Bantam Battery.

Instructions for:

QUANTUM BATTERY MODULE MF3

1. Turn the Quantum Battery 1+/1 OFF
2. Install the module into the flash as shown in diagram A.
3. Plug the module into one of the flash outputs on the Quantum Battery 1+/1.
4. Turn the Quantum Battery 1+/1 on.

If the flash does not power-up* within one second, turn the Quantum Battery 1+/1 OFF immediately**.

Instructions for:

BANTAM BATTERY MODULE XF3

1. Install the module into the flash as shown in diagram A.
2. Insert the plug of the module into the connector jack of the Bantam Battery.

If the flash does not power-up* within one second, remove the plug from the Bantam Battery immediately**.

NOTES:

*You can tell if the flash is powered-up by checking to see if the LCD Panel on the flash becomes active, or by listening for the whine of the flash recycling.

**If the flash does not respond, check to see if the module is correctly oriented inside the flash. If you still have difficulty, consult your dealer or contact us for assistance before proceeding.

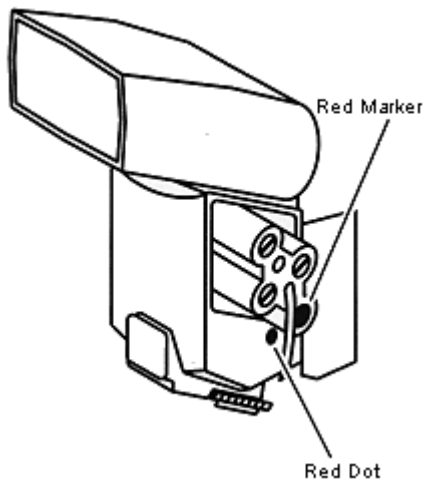

Diag. A

MODULE INSERTION

Insert the module into the battery compartment as shown in the diagram.

Note: The red polarity marker on the module should be closer to the rear of the flash.

Place one of the red dot stickers (included with the module) on the flash next to the red marker as a reminder for future use.

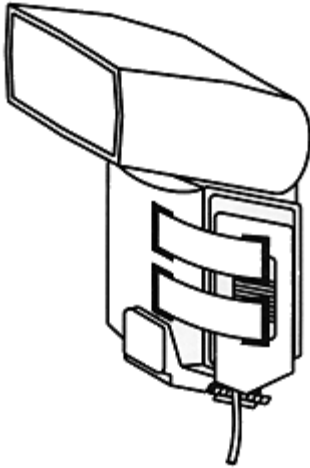

Diag. B

SECURING THE BATTERY DOOR

Push the module firmly into the battery compartment and slide the battery door on as far as possible.

Secure the door in place using the velcro pads and straps as shown in the diagram.

Any excess velcro strap can be trimmed to size with scissors if desired.

GRIPPER PLUG MOUNTING INSTRUCTIONS (FOR MF3)

Attached to one end of the flash module is Quantum's gripper plug. One of the important features of this plug is that it can be locked onto the battery! This is achieved by a simple mechanical process. The gripper plug eliminates the possibility of the plug becoming disconnected from the battery - at the worst possible time.

HOW TO USE:

1. Insert the module into the flash battery compartment as shown in the module instructions.
2. Before inserting the gripper plug into the Quantum Battery, loosen the shell until the locking fingers just start to become hidden under the shell. Insert the plug into the battery output jack until it is firmly seated. If you do not loosen the shell first, the plug will be difficult to insert into the battery (Fig. 1)
3. While holding the plug body, tighten the shell. It is not necessary to over-tighten the plug. Once you begin to feel resistance when tightening, you'll only need to tighten it 1/8 of a turn more to lock the plug onto the Quantum Battery. (Fig. 2)
4. To release the plug, loosen the shell about one turn and the plug can be disconnected from the battery.

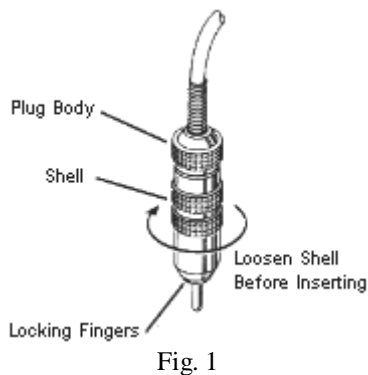

Fig. 1

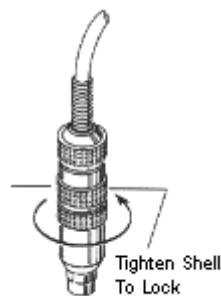

Fig. 2